

315

MODELLI MODELS	MOMENTO LIFTING MOMENT	SRACCIO ORIZZONTALE HORIZ. HYDRAULIC OUTREACH	PORTATA AL DISTRIBUTORE OIL FLOW TO THE CONTROL VALVE	SRACCIO MAX. VERTICALE MAX VERTICAL REACH	PESO SENZA STABILIZ. WEIGHT WITHOUT STAB.	PRESSIONE PRESSURE
	Tm	m	l/min	m	kg	bar
315A1	1.27	1.90	8	2.98	175	160
315A2	1.26	2.79	8	3.80	200	160

Autocarro consigliato - Recommended truck - Camion conseillé - Camion aconsejado
M.T.T. ton 2 - G.V.W. ton 2

STANDARD **STANDARD CE**



315 A1

m	1.08	1.90	2.79	3.67
kg	1175	665	445	315

315 A2

m	1.15	1.97	2.79	3.67
kg	1100	630	435	315

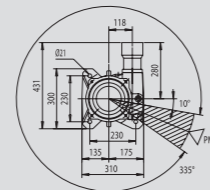
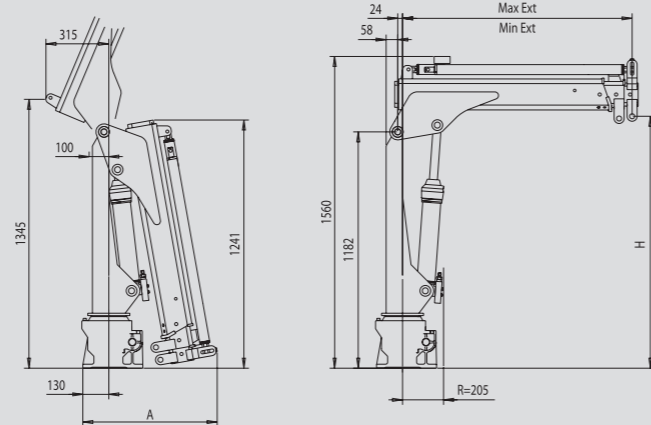

VERSION	A (mm)	H (mm)	Min Ext (mm)	Max Ext (mm)
A1	620	1249	1083	1903
A2	672	1260	1148	2788

**SPAZIO RICHIESSO PER L'INSTALLAZIONE
NECESSARY SPACE FOR INSTALLATION**

315	
315A1	410
315A2	410



F.lli FERRARI CORPORATION S.p.A.
Via Einstein, 8
42028 Poviglio (RE) Italy
Tel. +39 0522/486311
Fax +39 0522/486330
E-mail: marketing@fliferrari.it
www.fliferrari.com



M.K.T. 5800772 - Data di stampa - Date of printing - Date d'impression - Zeitpunkt des Drucks - Fecha de impresión: 01/03/2011.



FERRARI
315

315



F.LLI FERRARI CORPORATION S.p.A.

- Dati, descrizioni e illustrazioni sono relativi solo ed unicamente ai modelli commercializzati alla data di stampa di questo depliant. Successivamente alla data di stampa queste informazioni sono meramente indicative e non impegnano F.lli Ferrari. Eventuali variazioni sono a discrezione di F.lli Ferrari e sono sempre nel rispetto delle normative di sicurezza pertinenti ed applicabili. Per ottenere dati, descrizioni ed illustrazioni aggiornati, fare riferimento al costruttore o al rivenditore. Gru prodotte e/o commercializzate da F.lli Ferrari. - Data, descriptions and illustrations pertain only and uniquely to models sold at the time of printing of this brochure. After the date of printing, this information is purely indicative and not binding upon F.lli Ferrari. Future modifications are solely at the discretion of F.lli Ferrari and are always in compliance with applicable and pertinent safety standards. To obtain updated data, descriptions and illustrations, contact the manufacturer or your reseller. Cranes manufactured and/or marketed by F.lli Ferrari. - Les données, les descriptions et les illustrations se rapportent seulement et exclusivement aux modèles commercialisés à la date d'impression de ce dépliant. Après la date d'impression, ces informations sont simplement indicatives et n'engagent pas F.lli Ferrari. D'éventuelles modifications sont à la discrétion de F.lli Ferrari et toujours dans l'observance des normes de sécurité pertinentes et applicables. Pour obtenir les données, les descriptions et les illustrations actualisées, s'adresser au fabricant ou au revendeur. Grues produites et/ou vendues par F.lli Ferrari. - Daten, Beschreibungen und Abbildungen beziehen sich ausschließlich auf die zum Zeitpunkt des Drucks dieser Broschüre vertriebenen Modelle. Nach diesem Datum verstehen sich diese Informationen als rein richtungweisend und sind in keinem Fall für F.lli Ferrari verbindlich. F.lli Ferrari behält sich vor, nach eigenem Ermessen und in jedem Fall unter Berücksichtigung der zugehörigen und geltenden Sicherheitsvorschriften Änderungen vorzunehmen. Bitte wenden Sie sich für aktuelle Daten, Beschreibungen und Abbildungen an den Hersteller oder Händler. Die Kräne werden von F.lli Ferrari hergestellt und/oder vermarktet. - Los datos, descripciones e ilustraciones corresponden únicamente a los modelos comercializados hasta la fecha de impresión de este folleto. Después de la fecha de impresión estos datos son solo como referencia y no comprometen a F.lli Ferrari. Las posibles variaciones son a discreción de F.lli Ferrari y son conformes a las normas de seguridad pertinentes y aplicables. Para obtener datos, descripciones e ilustraciones actualizadas, dirigirse al fabricante o al distribuidor. Gruas producidas y/o comercializadas por F.lli Ferrari.

FERRARI® 315



I

La gru F.Ili Ferrari 315 racchiude in sé caratteristiche tecniche e meccaniche di elevata qualità

- Acciai ad alto limite di snervamento
- Basamento in fusione
- Struttura interamente sabbiata
- Sbracci fino a 2,79 m (3,67 m con prolunghe meccaniche)
- Valvola di sicurezza flangiata
- Limitatore di momento (CE)
- Boccole autolubrificanti
- Raccorderia SAE JIC 1514I
- Gancio girevole
- Kit di montaggio compreso
- Pannello comandi posizionabile a piacere
- Carter di protezione comandi in ABS
- Sistema di rotazione con vite senza fine
- Martinetti sfilo indipendenti
- Pattini di scorrimento sugli elementi telescopici
- Kit segnale luminoso aste chiuse (CE)
- Piattello stabilizzatore snodato
- Trasduttore proporzionale di pressione sul cilindro principale (CE)
- Sensore di corretto ripiegamento della gru (CE)
- Luce 90%-100% visibile da tutti i lati della gru (CE) (con radiocomando)
- Blocco rotazione meccanica (CE)

Accessori

- Traversa per stabilizzatori gru (singola o doppia)
- Stabilizzatori allargabili manualmente
- Stabilizzatori girevoli allargabili manualmente
- Traversa supplementare
- Radiocomando
- Prolonghe meccaniche
- RLC
- Serbatoio
- Centralina elettroidraulica
- Verricello idraulico

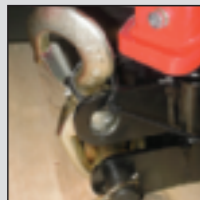

GB

The crane model 315 by F.Ili Ferrari has been designed and manufactured with high quality technical and mechanical characteristics

- High tensile strength steel
- Cast base
- Structure fully sandblasted
- Hydraulic outreach to 2,79 m (3,67 m with mechanical extensions)
- Flanged valve
- Load limiting device (CE)
- Self-lubricating bushings
- SAE JIC 1514I fittings
- Swivel load hook
- Mounting kit included
- Control panel with customizable position
- ABS protective cover on controls
- Worm screw slewing
- Independent telescopic cylinders
- Sliding pads on telescopic extensions
- Light indicator for correct stabilizer stowing (CE)
- Swivel outrigger foot
- Proportional pressure transducer on main cylinder (CE)
- Sensor for correct stowing of the crane (CE)
- 90%-100% light visible from all around the crane (CE) (with radio remote control)
- Mechanical slewing limitation (CE)

Accessories

- Tubular base for crane stabilizers (single or double)
- Manually opening outriggers
- Manually opening and turning outriggers
- Extra cross beams
- Radio remote control
- Manual extensions
- RLC
- Oil tank
- Electro-hydraulic powerpack
- Hydraulic winch



F

La grue modèle 315 F.Ili Ferrari est conçue avec des caractéristiques techniques et mécaniques de la plus haute qualité

- Acier à résistance élevée
- Embase moulé
- Structure complètement sablée
- Portée hydraulique jusqu'à 2,79 m (3,67 m avec rallonges mécaniques)
- Soupape de sûreté bridée
- Limiteur de moment (CE)
- Douilles autolubrifiantes
- Raccords SAE-JIC 1514I
- Crochet tournant
- Kit de montage inclus
- Panneau de commandes à positionner selon la demande
- Enveloppe de protection commande en ABS
- Rotation par vis sans fin
- Vérins hydrauliques indépendants
- Patins de coulissement sur les éléments télescopiques
- Kit capteurs de replies de béquilles stabilisatrices (CE)
- Plat d'appui béquille avec joint à rotule
- Capteur de pression proportionnel sur le vérin de levage (CE)
- Capteur de position "grue repliée" (CE)
- Colonne tricolore indiquant le statut de charge (90%-100%) visible de tous les côtés de la grue (CE) (seulement avec radiocommande)
- Limitation mécanique de la rotation (CE)

Accessoires

- Traversa stabilisatrice (simple ou double) en profil tubulaire
- Béquilles à ouverture manuelle
- Béquilles tournantes à ouverture manuelle
- Béquilles supplémentaires
- Radiocommande
- Rallonges mécaniques
- RLC
- Réservoir pour huile
- Pompe électro-hydraulique
- Treuil hydraulique



D

Das Kranmodell 315 vom F.Ili Ferrari ist mit höchsten Qualität für technischen und mechanischen Eigenschaften projiziert und hergestellt worden

- Stahl mit hoher Fließgrenze
- Gussockel
- Sandstrahlen der Struktur
- Hydraulische Reichweite bis 2,79 m (3,67 m mit mechanischen Ausschübe)
- Geflanschte Sicherheitventil
- Momentbegrenzer (CE)
- Selbstschmierende Buchsen
- SAE JIC 1514I Anschlüsse
- Schwenkbarer Haken
- Einsatzbau eingeschlossen
- Bedienungslage nach Wunsch
- Bedienungsschutz bei ABS
- Drehung bei Schnecke
- Unabhängige hydraulischen Hebers
- Gleitschuhe auf den Ausschübe
- Warmleuchte für Abstützungen (CE)
- Abstützbeine mit Gelenkfüßen
- Proportionaler Druckwandler am Hauptzylinder (CE)
- Sensor für die korrekte Zusammenfaltung des Kranes (CE)
- Licht 90%-100% sichtbar von allen Seiten des Kranes (CE) (nur mit Funksteuerung)
- Mechanische Schwenkbegrenzung (CE)

Zubehör

- Abstütztraverse (einseitig oder beidseitig)
- Handöffnung der Abstützungen
- Handöffnung der drehbare Abstützungen
- Zusatzabstützungen
- Funksteuerung
- Mechanische Verlängerungen
- RLC
- Ölbehälter
- Elektro-hydraulisch Schaltgerät
- Hydraulische Seilwinde



SP

El modelo de la grúa 315 de F.Ili Ferrari se ha proyectado y fabricado con características técnicas y mecánicas de alta calidad

- Acero en el alto borde de rendimiento
- Base moldeada
- Estructura completamente arenada
- Alcances hidráulicos hasta 2,79 m (3,67 m con prolongas mecánicas)
- Válvula de seguridad ensanchada
- Limitador de carga (CE)
- Casquillos autolubrificantes
- Racorería SAE-JIC 1514I
- Gancho giratorio
- Kit de montaje incluido
- Cuadro de mando desplazable
- Carter de protección en ABS
- Rotación mediante tornillo sin fin
- Prolongas independientes
- Patines de deslizamiento sobre las prolongas telescópicas
- Indicador luminoso de estabilizadores cerrados (CE)
- Plato de apoyo de patas articulada
- Transductor proporcional de presión sobre el cilindro principal (CE)
- Sensor de plegado correcto de la grúa (CE)
- Luz 90%-100% visible desde todas partes de la grúa (CE) (sólo con mando a distancia)
- Bloqueo rotación mecánica (CE)

Accesorios

- Travesaño para estabilizadores de grúa (simple o doble)
- Patas apertura manual
- Patas giratorias apertura manual
- Patas adicionales
- Mando a distancia
- Prolongas mecánicas
- RLC
- Depósito de aceite
- Central electro-hidráulica
- Cabestrante hidráulico

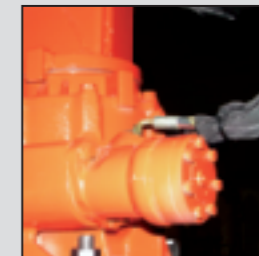
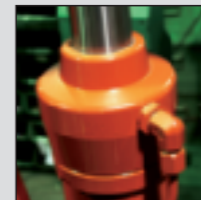

Sistemi di controllo stabilità (CE)
Stability control systems (CE)

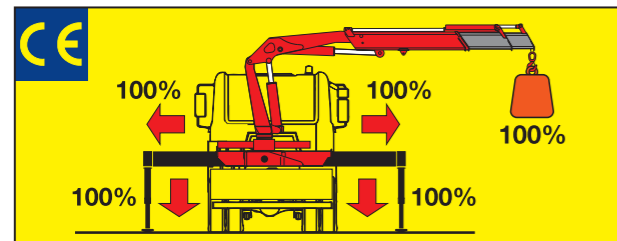

FS System

L' FS System integrato nel limitatore di momento controlla la posizione degli stabilizzatori. Solo quando tutte le aste sono completamente aperte e tutti gli stabilizzatori sono appoggiati a terra la gru può operare e sollevare il carico.

The FS System integrated in the load limiting device checks the stabilizers' positions. Only when all beams are fully open and all stabilizers are on the ground the crane can operate and lift loads.

Control display



Radio Remote Control Version "R"

FML System



L' FML System presente nella versione con radiocomando, integra il sistema di controllo stabilità con un display che riporta le informazioni utili per una migliore performance della gru.

The FML System equipped on cranes with radio remote control integrates the stability control system with a display which shows useful information for better crane performance.

Control display



Questo dispositivo visualizza su un display collocato in prossimità dei comandi il carico applicato al gancio della gru, rendendo l'utilizzo delle prolunghe meccaniche sicuro secondo la normativa europea EN 12999.

This device shows the load at the hook on a display placed near the controls, making safe the use of the mechanical booms following the European rule EN 12999.



315R

RADIO REMOTE CONTROL



The operator can control the crane with high precision proportional levers in every position and, doing so, can supervise the loading and unloading operations. That means a great time saving and a higher safety.

All the remote controls used by F.Ili FERRARI CORPORATION have an identification code and are shielded from electromagnetic fields and from external radio signals.

