

314

A HYVA GROUP COMPANY

MODELLI MODELS	MOMENTO LIFTING MOMENT	SBRACCIO ORIZZONTALE HORIZ. HYDRAULIC OUTREACH	PORTATA AL DISTRIBUTORE OIL FLOW TO THE CONTROL VALVE	SBRACCIO MAX. VERTICALE MAX VERTICAL REACH	PESO SENZA STABILIZ. WEIGHT WITHOUT STAB.	PRESSIONE PRESSURE
	tm	m	l/min	m	kg	bar
314A1	1.27	1.90	8	2.98	175	160
314A2	1.26	2.79	8	3.80	200	160

Autocarro consigliato - Recommended truck - Camion conseillé - Camion aconsejado
M.T.T. ton 2 - G.V.W. ton 2

STANDARD

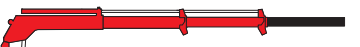

314 A1	314 A2
	
m	m
kg	kg
1.08	1.15
995	995
1.90	1.97
665	630
2.79	2.79
445	435
3.67	3.67
315	315

DIMENSIONS

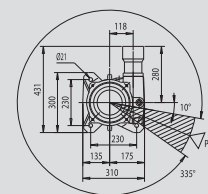
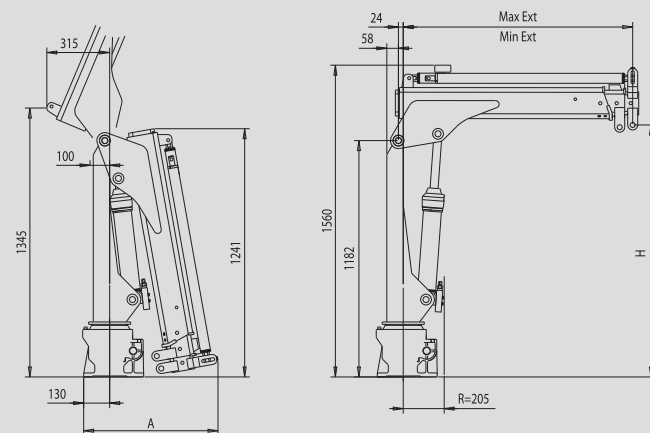

VERSION	A (mm)	H (mm)	Min Ext (mm)	Max Ext (mm)
A1	620	1249	1083	1903
A2	672	1260	1148	2788

SPAZIO RICHIESTO PER L'INSTALLAZIONE NECESSARY SPACE FOR INSTALLATION

314	
314A1	410
314A2	410



F.lli FERRARI
Via Einstein, 8
42028 Poggio (RE) Italy
Tel. +39 0522/486308
Fax +39 0522/486330
marketing@flliferrari.it
www.flliferrari.com



M.K.T. 5800362 - Data di stampa - Date of printing - Zeitpunkt des Drucks - Fecha de impresión: 01/10/2018.



314

314



Dati, descrizioni e illustrazioni sono relativi solo ed unicamente ai modelli commercializzati alla data di stampa di questo depliant. Successivamente alla data di stampa queste informazioni sono meramente indicative e non impegnano F.lli Ferrari. Eventuali variazioni sono a discrezione di F.lli Ferrari e sono sempre nel rispetto delle normative di sicurezza pertinenti ed applicabili. Per ottenere dati, descrizioni ed illustrazioni aggiornati, fare riferimento al costruttore o al rivenditore. Gru prodotte e/o commercializzate da F.lli Ferrari. - Data, descriptions and illustrations pertain only and uniquely to models sold at the time of printing of this brochure. After the date of printing, this information is purely indicative and not binding upon F.lli Ferrari. Future modifications are solely at the discretion of F.lli Ferrari and are always in compliance with applicable and pertinent safety standards. To obtain updated data, descriptions and illustrations, contact the manufacturer or your reseller. Cranes manufactured and/or marketed by F.lli Ferrari. - Les données, les descriptions et les illustrations se rapportent seulement et exclusivement aux modèles commercialisés à la date d'impression de ce dépliant. Après la date d'impression, ces informations sont simplement indicatives et n'engagent pas F.lli Ferrari. D'éventuelles modifications sont à la discrétion de F.lli Ferrari et toujours dans l'observance des normes de sécurité pertinentes et applicables. Pour obtenir les données, les descriptions et les illustrations actualisées, s'adresser au fabricant ou au revendeur. Grues produites et/ou vendues par F.lli Ferrari. - Daten, Beschreibungen und Abbildungen beziehen sich ausschließlich auf die zum Zeitpunkt des Drucks dieser Broschüre vertriebenen Modelle. Nach diesem Datum verstehen sich diese Informationen als rein richtungweisend und sind in keinem Fall für F.lli Ferrari verbindlich. F.lli Ferrari behält sich vor, nach eigenem Ermessen und in jedem Fall unter Berücksichtigung der zugehörigen und geltenden Sicherheitsvorschriften Änderungen vorzunehmen. Bitte wenden Sie sich für aktuelle Daten, Beschreibungen und Abbildungen an den Hersteller oder Händler. Die Krane werden von F.lli Ferrari hergestellt und/oder vermarktet. - Los datos, descripciones e ilustraciones corresponden únicamente a los modelos comercializados hasta la fecha de impresión de este folleto. Después de la fecha de impresión estos datos son sólo como referencia y no comprometen a F.lli Ferrari. Las posibles variaciones son a discreción de F.lli Ferrari y son conformes a las normas de seguridad pertinentes y aplicables. Para obtener datos, descripciones e ilustraciones actualizadas, dirigirse al fabricante o al distribuidor. Gruas producidas y/o comercializadas por F.lli Ferrari.

I

La gru F.III Ferrari 314 racchiude in sé caratteristiche tecniche e meccaniche di elevata qualità

- Acciai ad alto limite di snervamento
- Basamento in fusione
- Struttura interamente sabbiata
- Sbracci fino a 2,79 m (3,67 m con prolunghe meccaniche)
- Valvola di sicurezza flangiata
- Boccole autolubrificanti
- Raccorderia SAE JIC 1514I
- Gancio girevole
- Kit di montaggio compreso
- Pannello comandi posizionabile a piacere
- Carter di protezione comandi in ABS
- Sistema di rotazione con vite senza fine
- Martinetti sfilo indipendenti
- Pattini di scorrimento sugli elementi telescopici
- Kit segnale luminoso aste chiuse (CE)
- Piattello stabilizzatore snodato
- Blocco rotazione meccanica (CE)
- RLC

Accessori

- Traversa per stabilizzatori gru (singola o doppia)
- Stabilizzatori allargabili manualmente
- Stabilizzatori girevoli allargabili manualmente
- Traversa supplementare
- Radiocomando
- Prolunghe meccaniche
- Serbatoio
- Centralina elettroidraulica
- Verricello idraulico



GB

The crane model 314 by F.III Ferrari has been designed and manufactured with high quality technical and mechanical characteristics

- High tensile strength steel
- Cast base
- Structure fully sandblasted
- Hydraulic outreach to 2,79 m (3,67 m with mechanical extensions)
- Flanged valve
- Self-lubricating bushings
- SAE JIC 1514I fittings
- Swivel load hook
- Mounting kit included
- Control panel with customizable position
- ABS protective cover on controls
- Worm screw slewing
- Independent telescopic cylinders
- Sliding pads on telescopic extensions
- Light indicator for correct stabilizer stowing (CE)
- Swivel outrigger foot
- Mechanical slewing limitation (CE)
- RLC

Accessories

- Tubular base for crane stabilizers (single or double)
- Manually opening outriggers
- Manually opening and turning outriggers
- Extra cross beams
- Radiocommande
- Manual extensions
- Oil tank
- Electro-hydraulic powerpack
- Hydraulic winch



F

La grue modèle 314 F.III Ferrari est conçue avec des caractéristiques techniques et mécaniques de la plus haute qualité

- Acier à résistance élevée
- Embase moulé
- Structure complètement sablée
- Portée hydraulique jusqu'à 2,79 m (3,67 m avec rallonges mécaniques)
- Soupape de sûreté bridée
- Douilles autolubrifiantes
- Raccords SAE-JIC 1514I
- Crochet tournant
- Kit de montage inclus
- Panneau de commandes à positionner selon la demande
- Enveloppe de protection commande en ABS
- Rotation par vis sans fin
- Vérins hydrauliques indépendants
- Patins de coulissement sur les éléments télescopiques
- Kit capteurs de replies de béquilles stabilisatrices (CE)
- Plat d'appui béquille avec joint à rotule
- Capteur de position "grue repliée" (CE)
- Limitation mécanique de la rotation (CE)
- RLC

Accessoires

- Traversa stabilisatrice (simple ou double) en profil tubulaire
- Béquilles à ouverture manuelle
- Béquilles tournantes à ouverture manuelle
- Béquilles supplémentaires
- Radiocommande
- Rallonges mécaniques
- Réservoir pour huile
- Pompe électro-hydraulique
- Treuil hydraulique



CE

D

Das Kranmodell 314 vom F.III Ferrari ist mit höchsten Qualität für technischen und mechanischen Eigenschaften projiziert und hergestellt worden

- Stahl mit hoher Fließgrenze
- Gusssockel
- Sandstrahlen der Struktur
- Hydraulische Reichweite bis 2,79 m (3,67 m mit mechanischen Ausschübe)
- Geflanschte Sicherheitventil
- Selbstschmierende Buchsen
- SAE JIC 1514I Anschlüsse
- Schwenkbarer Haken
- Einsatzbau eingeschlossen
- Bedienungsanlage nach Wunsch
- Bedienungsschutz bei ABS
- Drehung bei Schnecke
- Unabhängige hydraulischen Hebers
- Gleitschuhe auf den Ausschübe
- Warnleuchte für Abstützungen (CE)
- Abstützbeine mit Gelenkfüßen
- Mechanische Schwenkbegrenzung (CE)
- RLC

Zubehör

- Abstütztraverse (einseitig oder beidseitig)
- Handöffnung der Abstützungen
- Handöffnung der drehbare Abstützungen
- Zusatzabstützungen
- Funksteuerung
- Mechanische Verlängerungen
- Ölbehälter
- Elektro-hydraulisch Schaltgerät
- Hydraulische Seilwinde



SP

El modelo de la grúa 314 de F.III Ferrari se ha proyectado y fabricado con características técnicas y mecánicas de alta calidad

- Acero en el alto borde de rendimiento
- Base moldeada
- Estructura completamente arenada
- Alcances hidráulicos hasta 2,79 m (3,67 m con prolongas mecánicas)
- Válvula de seguridad ensanchada
- Casquillos autolubrificantes
- Racorería SAE-JIC 1514I
- Gancho giratorio
- Kit de montaje incluido
- Cuadro de mando desplazable
- Carter de protección en ABS
- Rotación mediante tornillo sin fin
- Prolongas independientes
- Patines de deslizamiento sobre las prolongas telescópicas
- Indicador luminoso de estabilizadores cerrados (CE)
- Plato de apoyo de patas articulado
- Bloqueo rotación mecánica (CE)
- RLC

Accesorios

- Travesaño para estabilizadores de grúa (simple o doble)
- Patas apertura manual
- Patas giratorias apertura manual
- Patas adicionales
- Mando a distancia
- Prolongas mecánicas
- Depósito de aceite
- Central electro-hidráulica
- Cabestrante hidráulico

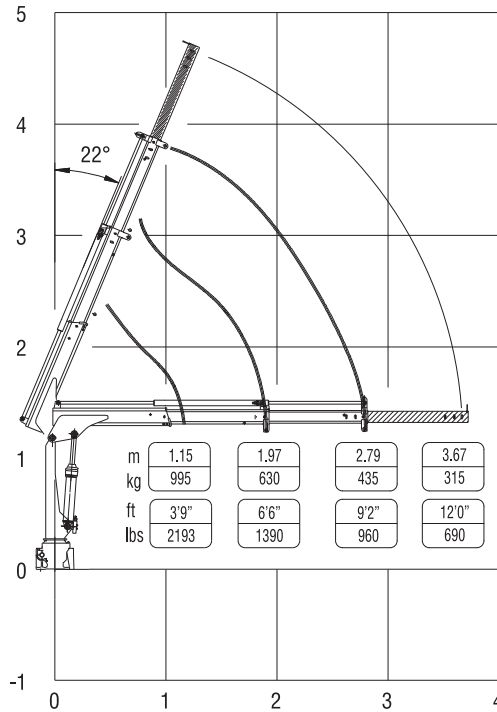

Questo dispositivo visualizza su un display collocato in prossimità dei comandi il carico applicato al gancio, rendendo l'utilizzo della gru e delle prolunghe meccaniche sicuro secondo la normativa europea EN 12999.

This device shows the load at the hook on a display placed near the controls, making safe the use of the crane and mechanical booms following the European rule EN 12999.



314R

RADIO REMOTE CONTROL



The operator can control the crane with high precision proportional levers in every position and, doing so, can supervise the loading and unloading operations. That means a great time saving and a higher safety.

All the remote controls used by F.III FERRARI CORPORATION have an identification code and are shielded from electromagnetic fields and from external radio signals.

