

9235C
NEW AGE



RADIOCONTROL

9235C

Ferrari

A HYVA GROUP COMPANY

9235C



**Extension Quick System
and Smart Extension Sequence**
Fast, precise, safe

Link on second boom
Boom negative angle allows
access to confined spaces

**Heavy duty hook
attachment**
Ruggedness and durability
in all applications

Link on column
Constant lifting capacity on all
main boom positions

Endless slewing
Efficient use in all the vehicle
positions

**Ergonomic control station
and user-friendly interface**
Comfortable, convenient and safe

Always stable
More than 40 stabilizer
combinations available

**Break the boundaries
in performance and
safety**

180E32 E6



7" color display
Simple and quick access to all the functions and information

Vertical stabilizer levers
Safe and fast. Excellent supervision of stabilizing operation

Ergonomic control station engineered for maximum operator comfort and ease of operation

Dynamic Load Diagram



Crane lifting capacity always under control in all stabilizer positions.
After the truck has been stabilized, the operator selects the load weight to be lifted. The display shows the permitted crane outreach based on the truck stability and load selected.

- Improved efficiency
- Easy to use
- Optimised safety

Magic Touch

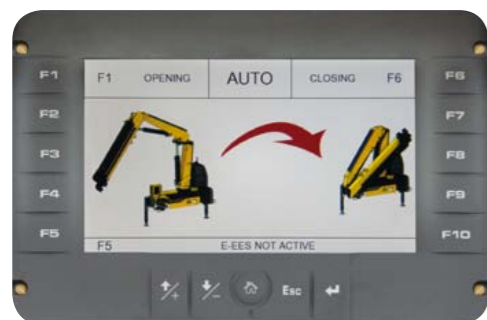

Crane Automatic folding/unfolding.
This system allows the operator to unfold the crane to a working position and fold the crane from any position to transport position by pressing a single button on the radio transmitter or display.

- Easy to start and close
- Save time
- Increased productivity and safety

High-tech development

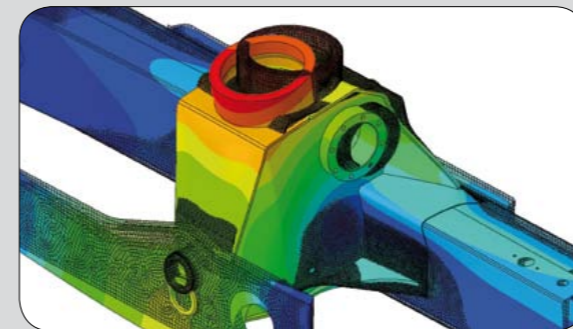

- Structures optimised for strength, weight and speed

Top Protection



- High value retention
- Top reliability

Endless performance

Continuous rotation and extreme flexibility
Endless slewing allows the crane to be operated without restrictions. The complete access to the working area, eliminates the need to reposition the truck, optimizing precision, productivity and safety.

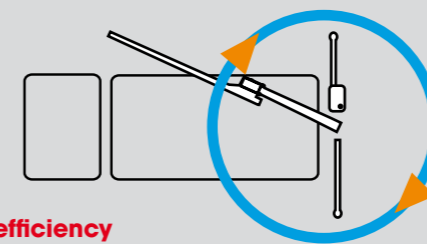

- Top efficiency
- Easy to use

Functional Aesthetic

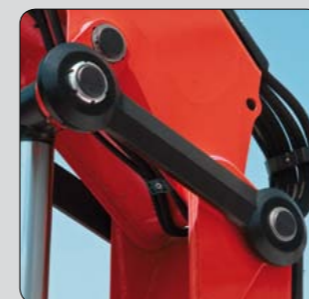

Forged double linkages on column and 2nd boom

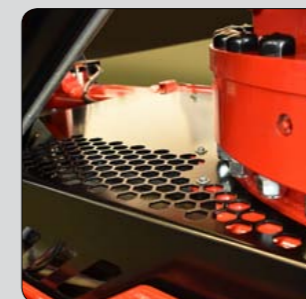

Hex Deck cover on base

Crane control system

F3XL

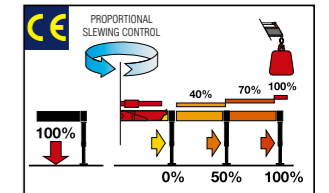

With a 3" TFT display and ergonomic keyboard, the crane operator can select optimum functional parameters. The system controls the stability with 2-step beam outreach monitoring and continuous slewing control.

F4XL+TOP

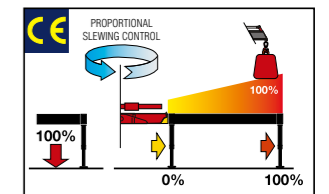

A 7" color display with integrated keyboard gives the operator a higher level of awareness of the crane operation and allows selection of the best parameters for effective use. The system detects the exact position of the beams and proportionally calculates the stability.

Wide range Radio selection (Standard)



Hetronic Not CE



Hetronic CE Basic



Scanreco



Hetronic CE Graphic



Powered by Danfoss

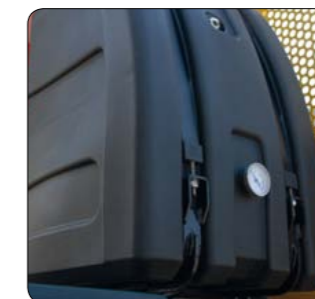

High volume oil tank made in sandwich-structured materials (PEX and PA6)



Robust column design and hoses cover

9235C Technical data

	Lifting Moment	Slewing Angle	Working pressure	Oil tank capacity	Max Oil flow	Max lifting height	Standard crane weight
	tm	°	bar	l	l/min	m	kg
A2	21,7	endless	345	130	80	12,0	2635
A3	21,2	endless	345	130	80	14,1	2785
A4	20,7	endless	345	130	80	16,2	2935
A5	20,3	endless	345	130	80	18,4	3055
A6	20,0	endless	345	130	80	20,7	3150
A3J3	17,5	endless	N/A	130	80	22,2	3445
A4J3	17,4	endless	N/A	130	80	23,8	3425
A5J2	11,7	endless	N/A	130	80	23,9	3330

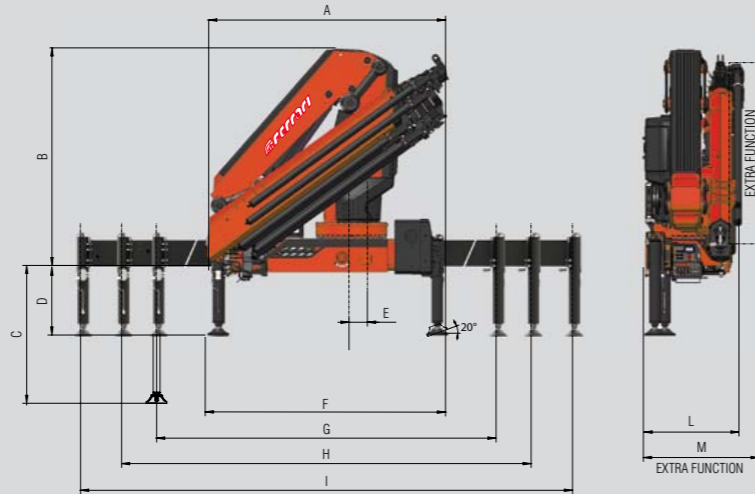

	A2	A3	A4	A5	A6	A3J3	A4J3	A5J2
A	2535	2535	2535	2535	2535	2575	2630	2530
B	2685	2685	2685	2685	2685	2685	2685	2685
C	1348	1348	1348	1348	1348	1348	1348	1348
D	611	611	611	611	611	611	611	611
E	250	250	250	250	250	250	250	250
F	2520	2520	2520	2520	2520	2520	2520	2520
G	4860	4860	4860	4860	4860	4860	4860	4860
H	5500	5500	5500	5500	5500	5500	5500	5500
I	7420	7420	7420	7420	7420	7420	7420	7420
L	960	960	960	960	960	1095	1095	1095
M	1080	1080	1080	1080	1080	-	-	-



RADIOCONTROL

Standard

- Designed in accordance with EN12999
- Design class: HC1-HD5
- Multifunctional radio remote control
- Sauer Danfoss PVG32
- P-PB Proportional Power Boost
- Flanged valves
- Oil tank
- Manually extendable stabilizers
- Fixed stabilizer cylinders
- Swivel stabilizer foot
- Centralized greasing system
- EQS Extension Quick System
- SDV Smooth Descent Valve
- Red Power
- F3XL Crane control system (CE)

Model	kg	m	kg	m	kg	m	kg	m	kg	m	kg	m
A2	5045	4,30	3405	6,27	2575	8,24						
A3	4920	4,30	3270	6,27	2430	8,24	1920	10,31	1465	12,38	1130	14,51
A4	4725	4,38	3105	6,35	2280	8,32	1775	10,39	1465	12,46	1130	14,67
A5	4545	4,46	2960	6,43	2150	8,40	1645	10,47	1345	12,54	1130	14,67
A6	4390	4,55	2850	6,52	2050	8,49	1555	10,56	1285	12,63	1060	14,76
A3J3					905	13,31	775	15,01	675	16,76	605	18,51
A4J3					715	15,38	635	16,94	570	18,50	520	20,06
A5J2					675	17,36	615	18,74	570	20,22		

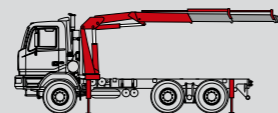

Recommended truck M.T.T. ton 18 - G.V.W. ton 18



One model, many applications



Waste handling



Construction



Fence posts, poles and landscaping



With winch



9235C

NEW AGE



Quality and environmental certified



F.lli FERRARI

Via Einstein, 8
42028 Poviglio (RE) Italy
Tel. +39 0522/486308
Fax +39 0522/486330
info@flliferrari.it
marketing@flliferrari.it
www.flliferrari.com

Dealer

Data, descriptions, and illustrations pertain only and uniquely to models sold at the time of printing of this brochure. After the date of printing this information is purely indicative and not binding upon F.lli Ferrari. Future modifications are solely at the discretion of F.lli Ferrari and are always in compliance with applicable and pertinent safety standards. To obtain updated data, descriptions, and illustrations, contact the manufacturer or your reseller. Cranes manufactured and/or marketed by F.lli Ferrari.