

7231C
NEW AGE



RADIOCONTROL

7231C

Ferrari

A HYVA GROUP COMPANY

7231C



RADIOCONTROL

Extension Quick System and Smart Extension Sequence
Fast, precise, safe

Link on second boom
Boom negative angle allows access to confined spaces

Link on column
Constant lifting capacity on all main boom positions

Ergonomic control station and user-friendly interface
Comfortable, convenient and safe

Always stable
More than 40 stabilizer combinations available

Break the boundaries in performance and safety



7" color display
Simple and quick access to all the functions and information

Vertical stabilizer levers
Safe and fast. Excellent supervision of stabilizing operation

Ergonomic control station engineered for maximum operator comfort and ease of operation

Dynamic Load Diagram



Crane lifting capacity always under control in all stabilizer positions.
After the truck has been stabilized, the operator selects the load weight to be lifted. The display shows the permitted crane outreach based on the truck stability and load selected.

- Improved efficiency
- Easy to use
- Optimised safety

Magic Touch

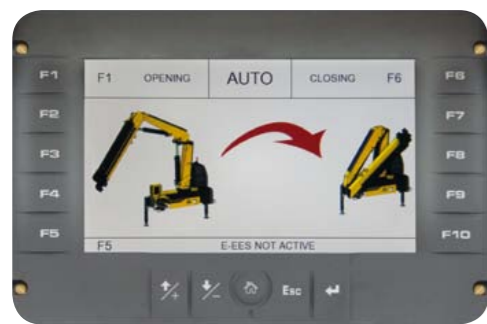

Crane Automatic folding/unfolding.
This system allows the operator to unfold the crane to a working position and fold the crane from any position to transport position by pressing a single button on the radio transmitter or display.

- Easy to start and close
- Save time
- Increased productivity and safety

High-tech development

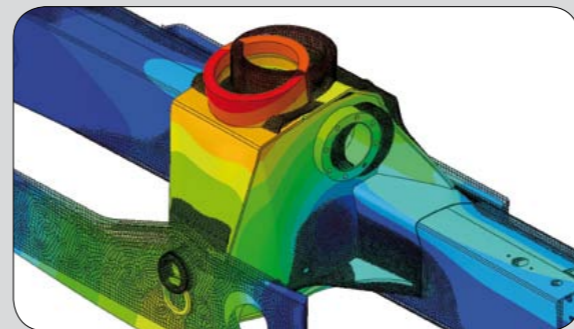

- Structures optimised for strength, weight and speed

Top Protection



- High value retention
- Top reliability

Negative angle



- More versatile
- Easier access in confined and low spaces

Functional Aesthetic



Forged double linkages on column and 2nd boom



Hex Deck cover on base

Crane control system

F3XL

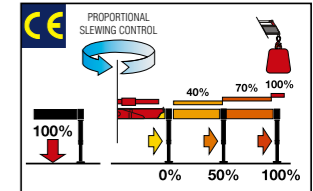

With a 3" TFT display and ergonomic keyboard, the crane operator can select optimum functional parameters. The system controls the stability with 2-step beam outreach monitoring and continuous slewing control.

F4XL+TOP

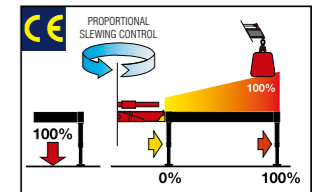

A 7" color display with integrated keyboard gives the operator a higher level of awareness of the crane operation and allows selection of the best parameters for effective use. The system detects the exact position of the beams and proportionally calculates the stability.

Wide range Radio selection (Standard)



Hetronic Not CE Hetronic CE Basic Scanreco



Hetronic CE Graphic



Powered by Danfoss

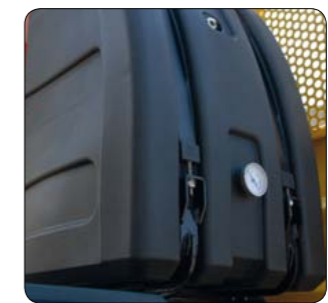

High volume oil tank made in sandwich-structured materials (PEX and PA6)



Robust column design and hoses cover

7231C Technical data

	Lifting Moment	Slewing Angle	Working pressure	Oil tank capacity	Max Oil flow	Max lifting height	Standard crane weight
	tm	°	bar	l	l/min	m	kg
A2	21,7	415	345	130	70	12,0	2475
A3	21,1	415	345	130	70	14,1	2625
A4	20,7	415	345	130	70	16,2	2775
A5	20,2	415	345	130	70	18,4	2895
A6	20,0	415	345	130	70	20,7	2990
A3J3	17,5	415	-	130	70	22,2	3285
A4J3	17,4	415	-	130	70	23,8	3265
A5J2	11,5	415	-	130	70	23,9	3170

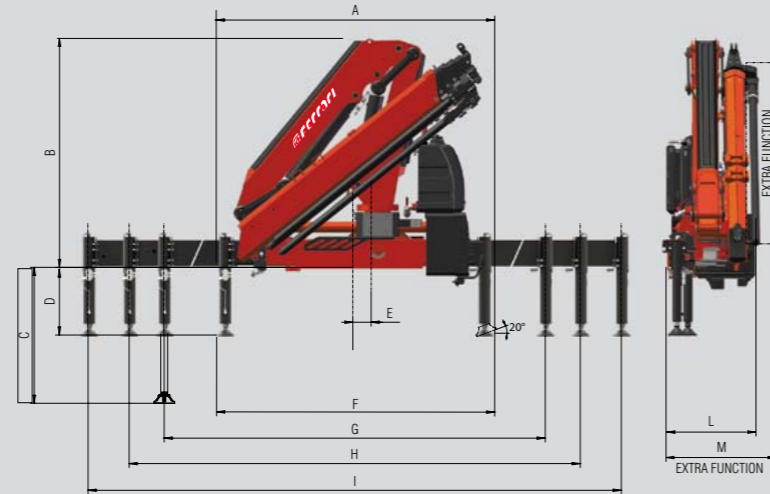

	A2	A3	A4	A5	A6	A3J3	A4J3	A5J2
A	2500	2500	2500	2500	2500	2500	2500	2500
B	2300	2300	2300	2300	2300	2670	2600	2550
C	1348	1348	1348	1348	1348	1348	1348	1348
D	666	666	666	666	666	666	666	666
E	150	150	150	150	150	150	150	150
F	2520	2520	2520	2520	2520	2520	2520	2520
G	4860	4860	4860	4860	4860	4860	4860	4860
H	5500	5500	5500	5500	5500	5500	5500	5500
I	7420	7420	7420	7420	7420	7420	7420	7420
L	930	930	930	930	930	1050	1050	1050
M	1050	1050	1050	1120	1120	-	-	-



Standard

- Designed in accordance with EN12999
- Design class: HC1-HD5
- Multifunctional radio remote control
- Sauer Danfoss PVG32
- P-PB Proportional Power Boost
- Flanged valves
- Oil tank
- Manually extendable stabilizers
- Fixed stabilizer cylinders
- Swivel stabilizer foot
- Centralized greasing system
- EQS Extension Quick System
- SDV Smooth Descent Valve
- Red Power
- F3XL Crane control system (CE)

A2	kg	5045	3405	2575					
	m	4,30	6,27	8,24					
A3	kg	4920	3270	2430	1920	1465	1130	725	
	m	4,30	6,27	8,24	10,31	12,46	14,68	16,96	
A4	kg	4725	3105	2280	1775	1465	1130	890	600
	m	4,38	6,35	8,32	10,39	12,46	14,67	16,96	19,06
A5	kg	4545	2960	2150	1645	1345	1130	890	755
	m	4,46	6,43	8,40	10,47	12,54	14,67	16,96	19,06
A6	kg	4390	2850	2050	1555	1285	1060	895	755
	m	4,55	6,52	8,49	10,56	12,63	14,76	16,96	19,06
A3J3	kg				905	775	675	605	
	m				13,31	15,01	16,76	18,51	
A4J3	kg					715	635	570	520
	m					15,38	16,94	18,50	20,06
A5J2	kg						675	615	570
	m						17,36	18,74	20,22

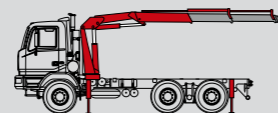

Recommended truck M.T.T. ton 19 - G.V.W. ton 19



One model, many applications



Waste handling



Construction



Fence posts, poles and landscaping



With winch



7231C
NEW AGE



Quality and environmental certified



F.lli FERRARI

Via Einstein, 8
42028 Poviglio (RE) Italy
Tel. +39 0522/486308
Fax +39 0522/486330
info@flliferrari.it
marketing@flliferrari.it
www.flliferrari.com

Dealer

Data, descriptions, and illustrations pertain only and uniquely to models sold at the time of printing of this brochure. After the date of printing this information is purely indicative and not binding upon F.lli Ferrari. Future modifications are solely at the discretion of F.lli Ferrari and are always in compliance with applicable and pertinent safety standards. To obtain updated data, descriptions, and illustrations, contact the manufacturer or your reseller. Cranes manufactured and/or marketed by F.lli Ferrari.