

B Series
NEW AGE



7090B
7112B

Ferrari

A HYVA GROUP COMPANY

7090B - 7112B Technical data

	Lifting Moment	Swiveling Angle	Working pressure	Oil tank capacity	Max Oil flow	Max lifting height	Standard crane weight
	tm	°	bar	l	l/min	m	kg
7090B							
A1	8,7	425	310	75	40	9,1	1140
A2	8,2	425	310	75	40	10,7	1220
A3	8,0	425	310	75	40	12,6	1300
A4	7,8	425	310	75	40	14,4	1370
7112B							
A1	10,5	425	300	75	40	9,3	1215
A2	10,1	425	300	75	40	10,9	1320
A3	9,5	425	300	75	40	12,6	1420
A4	9,3	425	300	75	40	14,6	1510

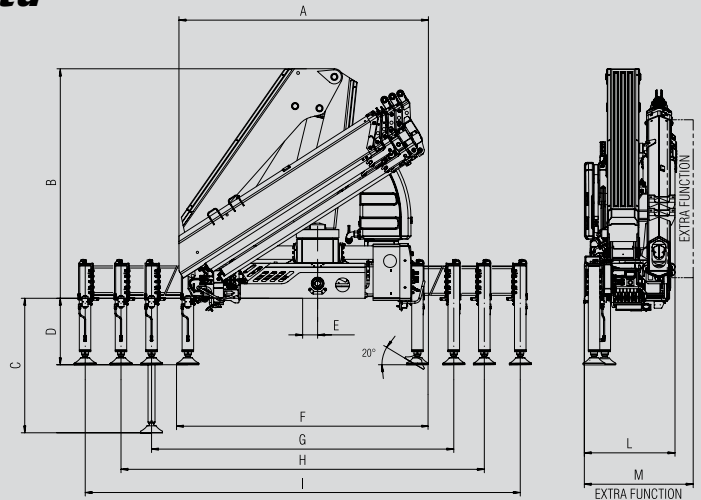

	A1		A2		A3		A4	
	7090	7112	7090	7112	7090	7112	7090	7112
A	2305	2310	2305	2310	2305	2310	2305	2310
B	2070	2095	2070	2095	2070	2095	2070	2095
C	1185	1327	1185	1327	1185	1327	1185	1327
D	585	635	585	635	585	635	585	635
E	160	160	160	160	160	160	160	160
F	2270	2303	2270	2303	2270	2303	2270	2303
G	3290	3300	3290	3300	3290	3300	3290	3300
H	4790	4805	4790	4805	4790	4805	4790	4805
I	5755	5765	5755	5765	5755	5765	5755	5765
L	800	800	800	800	800	800	800	800
M	850	850	850	850	850	850	850	850

A1	kg	2155	1520				7090B
	m	4,03	5,71				
A2	kg	2610	1835				7112B
	m	4,05	5,74				
A3	kg	2045	1425	1100	710	600	7090B
	m	4,03	5,71	7,40	9,36	11,16	
A4	kg	2505	1730	1330	870	720	7112B
	m	4,06	5,74	7,43	9,31	11,18	
A3	kg	1940	1330	995	790	600	7090B
	m	4,12	5,80	7,49	9,29	11,16	13,17
A4	kg	2310	1575	1190	955	720	7112B
	m	4,14	5,82	7,51	9,31	11,18	13,22
A4	kg	1870	1240	925	710	600	7090B
	m	4,19	5,87	7,56	9,36	11,16	13,17
A4	kg	2210	1495	1110	870	720	7112B
	m	4,22	5,90	7,59	9,39	11,19	13,22

Standard

- Designed in accordance with EN12999
- Design class: HC1-HD4
- Cross controls
- Flanged valves
- Oil tank
- Manually extendable stabilizers
- Fixed stabilizer cylinders
- Swivel stabilizer foot
- Centralized greasing system
- EQS Extension Quick System
- SDV Smooth Descent Valve
- F3XL Crane control system (CE)



F.lli FERRARI

Via Einstein, 8
42028 Poggio (RE) Italy
Tel. +39 0522/486308
Fax +39 0522/486330
info@fliferrari.it
marketing@fliferrari.it
www.fliferrari.com



Quality and environmental
certified

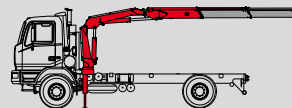

Recommended truck:
7090B - M.T.T. ton 8 - G.V.W. ton 8
7112B - M.T.T. ton 10 - G.V.W. ton 10

Dealer

Data, descriptions, and illustrations pertain only and uniquely to models sold at the time of printing of this brochure. After the date of printing, this information is purely indicative and not binding upon F.lli Ferrari. Future modifications are solely at the discretion of F.lli Ferrari and are always in compliance with applicable and pertinent safety standards. To obtain updated data, descriptions, and illustrations, contact the manufacturer or your reseller. Cranes manufactured and/or marketed by F.lli Ferrari.