

# 581

MODELLI MODELS	MOMENTO LIFTING MOMENT	SBRACCIO ORIZZONTALE HORIZ. HYDRAULIC OUTREACH	PORTATA AL DISTRIBUTORE OIL FLOW TO THE CONTROL VALVE	SBRACCIO MAX. VERTICALE MAX VERTICAL REACH	PESO WEIGHT	PRESSIONE PRESSURE	INTERASSE STAB. STANDARD APERTI DISTANCE BETWEEN CENTRES WITH OPENED OUTRIGGERS	INTERASSE STAB. EXTRA APERTI EXTRA WIDE DISTANCE BETWEEN CENTRES WITH OPENED OUTRIGGERS
	Tm.	m.	L.min	m.	Kg	bar	mm.	mm.
581 A1	7.9	5.55	20	8.50	910	285	3370	4600
581 A2	7.7	7.20	20	10.20	990	285	3370	4600
581 A3	7.4	8.81	20	11.70	1050	285	3370	4600
581 A4	7.2	10.50	20	13.30	1110	285	3370	4600
581 A3J2	/	13.75	20	16.60	1260	285	3370	4600

Autocarro consigliato - Recommended truck - Camion conseillé - Camion aconsejado  
M.T.T. ton 9 - G.V.W. ton 9

### STANDARD



400°

Angolo di rotazione  
Stewing angle



135

Serbatoio olio  
Oil Tank

### STANDARD CE



Limitatore di momento  
Overload device

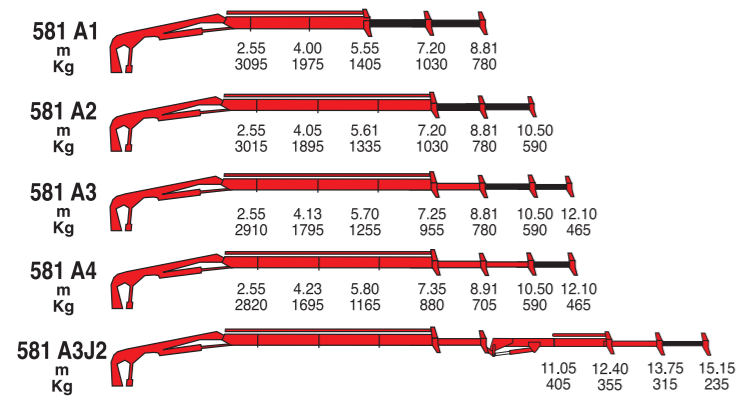

Dati, descrizioni e illustrazioni sono indicativi e non impegnano F.lli Ferrari. Gru prodotte e/o commercializzate da F.lli Ferrari - Data, descriptions and illustrations are merely indicative and not binding. Cranes manufactured and/or marketed by F.lli Ferrari - Les données, descriptions et illustrations sont uniquement indicatives et n'engagent pas F.lli Ferrari. Grues produites et/ou vendues par F.lli Ferrari - Angaben, Beschreibungen und Abbildungen sind weisend und verpflichten nicht F.lli Ferrari. Die Kräne werden von F.lli Ferrari hergestellt und/oder vermarktet - Los datos, las descripciones y las ilustraciones son indicativos y no implican compromiso para F.lli Ferrari. Gruas producidas y/o comercializadas por F.lli Ferrari - Os dados as descrições e ilustrações são indicativos e não comprometem F.lli Ferrari. Guindaste produzidos e/ou comercializados pela F.lli Ferrari.

COMPANY  
WITH QUALITY MANAGEMENT  
SYSTEM CERTIFIED BY DNV  
= ISO 9001/2000 =

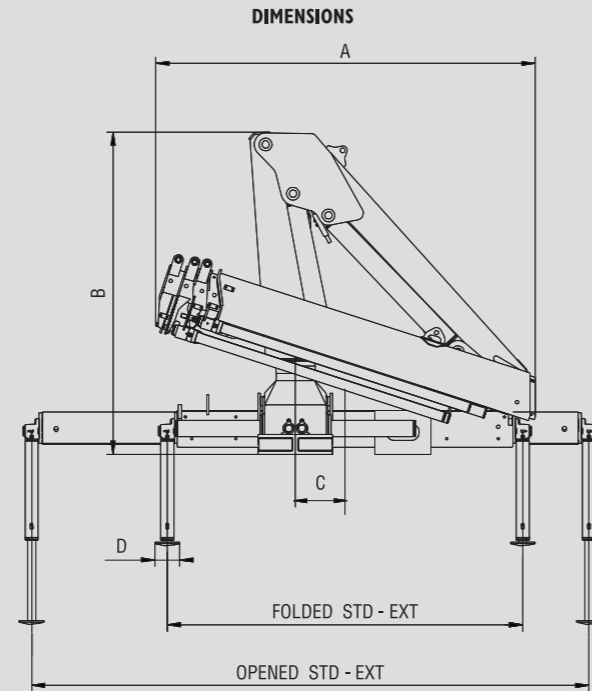

581	FOLDED				OPENED	
	A	B	C	STD	EXT	D
581 A1	2075	2000	300	2150	2150	150
581 A2	2150	2000	300	2150	2150	150
581 A3	2270	2000	300	2150	2150	150
581 A4	2300	2000	300	2150	2150	150
581 A3J2	2305	2000	300	2150	2150	150

### SPAZIO RICHIESTO PER L'INSTALLAZIONE NECESSARY SPACE FOR INSTALLATION

581	Con attivazioni - With extra function	
581 A1	600	730
581 A2	600	730
581 A3	600	730
581 A4	600	730
581 A3J2	730	-



F.lli FERRARI CORPORATION S.p.A.  
Via Pasubio, 3  
42022 Boretto (RE) Italy  
Tel. +39 0522/486311  
Fax +39 0522/486330  
E-mail: marketing@flliferrari.it  
www.flliferrari.com

M.K.T.5800253 01/09 3000



  
**581**

# 581



F.LLI FERRARI CORPORATION S.p.A.



# FERRARI® 581



I

La gru F.Ili Ferrari 581 racchiude in sé caratteristiche tecniche e meccaniche di elevata qualità

- Acciai ad alto limite di snervamento
- Struttura interamente sabbiata
- Basamento in fusione
- Bracci esagonali
- Sbracci fino a 10,50 m (12,10 m con prolunghe meccaniche)
- Valvole di sicurezza flangiata
- Comandi bilaterali
- Limitatore di momento (CE)
- Boccole autolubrificanti
- Raccorderia SAE JIC 1514I
- Gancio girevole
- Kit di montaggio compreso
- Stabilizzatori rotanti
- Pattini di scorrimento sugli elementi telescopici
- Kit segnale luminoso aste chiuse (CE)
- Blocco rotazione meccanica (CE)

**Accessori**

- Prolunghe meccaniche
- Stabilizzatori extrastendibili
- Traverse supplementari
- Comandi supplementari attivati
- Verricello idraulico
- Radiocomando
- Utilizzo con attrezzo
- Dispositivo di controllo RLC

GB

The crane model 581 by F.Ili Ferrari has been designed and manufactured with high quality technical and mechanical characteristics

- High tensile strength steel
- Structure fully sandblasted
- Cast base
- Hexagonal booms
- Hydraulic outreach to 10,50 m (12,10 m with mechanical extensions)
- Flanged valves
- Dual-side controls
- Load limiting device (CE)
- Self-lubricating bushings
- SAE JIC 1514I fittings
- Swivel load hook
- Mounting kit included
- Turning outriggers
- Sliding pads on telescopic extensions
- Light indicator for correct stabilizer stowing (CE)
- Mechanical slewing limitation (CE)

**Accessories**

- Mechanical extensions
- Extra wide outriggers
- Extra cross beams
- Extra functions
- Hydraulic winch
- Radio remote control
- Use with special equipments
- Load radio checking device RLC

F

La grue modèle 581 F.Ili Ferrari est conçue avec des caractéristiques techniques et mécaniques de la plus haute qualité

- Acier à résistance élevée
- Structure complètement sablée
- Embase moulé
- Extensions hexagonales
- Portée hydraulique jusqu'à 10,50 mt (12,10 mt avec rallonges mécaniques)
- Soupapes de sûreté bridées
- Commandes bilatérales
- Limiteur de moment (CE)
- Douilles autolubrifiantes
- Raccords SAE-JIC 1514I
- Crochet tournant
- Kit de montage inclus
- Béquilles tournantes
- Patins de coulissement sûr les éléments télescopiques
- Kit capteurs de replis de béquilles stabilisatrices (CE)
- Limitation mécanique de la rotation (CE)

**Accessoires**

- Rallonges mécaniques
- Béquilles extra larges
- Béquilles supplémentaires
- Circuits supplémentaires activés
- Treuil hydraulique
- Radiocommande
- Utilisation avec accessoires
- Dispositif de contrôle de la charge RLC

D

Das Kranmodell 581 vom F.Ili Ferrari ist mit höchsten Qualität für technischen und mechanischen Eigenschaften projiziert und hergestellt worden

- Stahl mit hoher Fließgrenze
- Sandstrahlen der Struktur
- Gussockel
- Sechswinklige Ausschübe
- Hydraulische Reichweite bis 10,50 m (12,10 m mit mechanischen Ausschübe)
- Geflanschte Sicherheitventile
- Beidseitigen Kransteuerungen
- Momentbegrenzer (CE)
- Selbstschmierende Buchsen
- SAE JIC 1514I Anschlüsse
- Schwenkbarer Haken
- Einsatzbau eingeschlossen
- Drehbare Ausschüben
- Gleitschuhe auf den Ausschüben
- Warnleuchte für Abstützungen (CE)
- Mechanische Schwenkbegrenzung (CE)

**Zubehore**

- Mechanische Verlängerungen
- Extra-breite Abstützungen
- Zusatzabstützungen
- Zusatzfunktionen
- Hydraulische Seilwinde
- Funksteuerung
- Benutzung mit Zubehören
- Vorrichtung für Lastkontrolle RLC

SP

El modelo de la grúa 581 de F.Ili Ferrari se ha proyectado y fabricado con características técnicas y mecánicas de alta calidad

- Acero en el alto borde de rendimiento
- Estructura completamente arenada
- Base moldeada
- Prolongas hexagonales
- Alcances hidráulicos hasta 10,50 m (12,10 m con prolongas mecánicas)
- Válvulas de seguridad ensanchadas
- Mandos bilaterales
- Limitador de carga (CE)
- Casquillos autolubrificantes
- Racoreria SAE-JIC 1514I
- Gancho giratorio
- Kit de montaje incluido
- Patas giratorias
- Patín de deslizamiento sobre las prolongas telescópicas
- Indicador luminoso de estabilizadores cerrados (CE)
- Bloqueo rotación mecánica (CE)

**Accesorios**

- Prolongas mecánicas
- Patas extra-largas
- Patas adicionales
- Activaciones adicionales
- Cabestrante hidráulico
- Radiomando
- Utilización con accesorios
- Dispositivo de verificación de la carga RLC

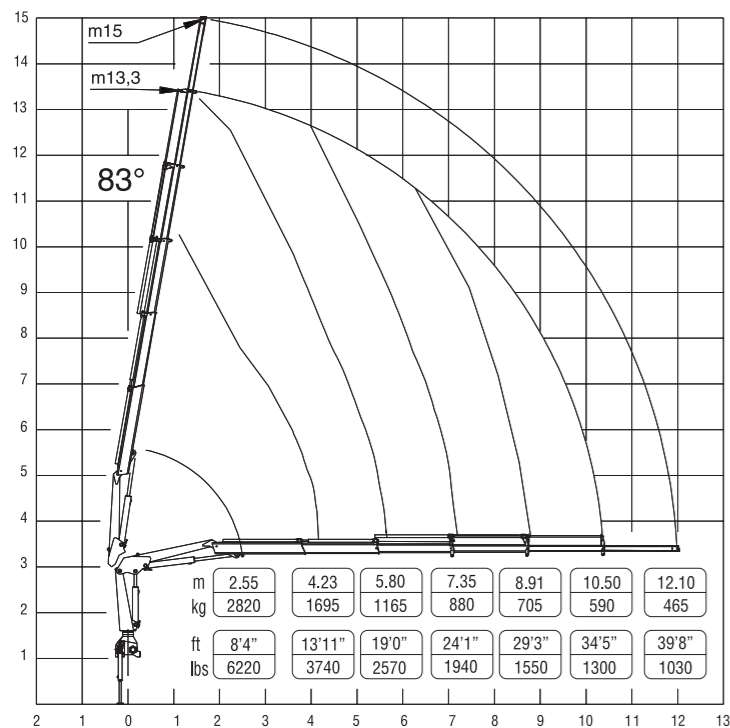
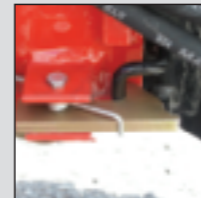
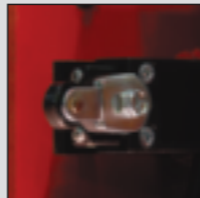
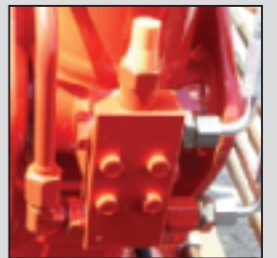
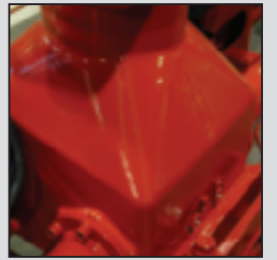

Questo dispositivo visualizza su un display collocato in prossimità dei comandi il carico applicato al gancio della gru, rendendo l'utilizzo delle prolunghe meccaniche sicuro secondo la normativa europea EN 12999.

This device shows the load at the hook on a display placed near the controls, making safe the use of the mechanical extensions following the European rule EN 12999.



## RADIO REMOTE CONTROL

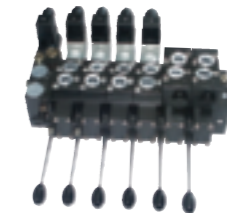

The operator can control the crane with high precision proportional levers in every position and, doing so, can supervise the loading and unloading operations. That means a great time saving and a higher safety.

All remote controls used by F.Ili FERRARI CORPORATION have an identification code and are shielded from electromagnetic fields and from external radio signals.

